

Cush'n Combo Assembly: 47090001

NOTE: SHIM TOP WEAR BLOCK (ITEM #5) AS REQUIRED SO THAT DRAW BAR WELDMENT (ITEM #2) CAN SWING AND EXTEND FREELY WITH 1/32" MAX CLEARANCE AT WEAR BLOCK (ITEM #5)

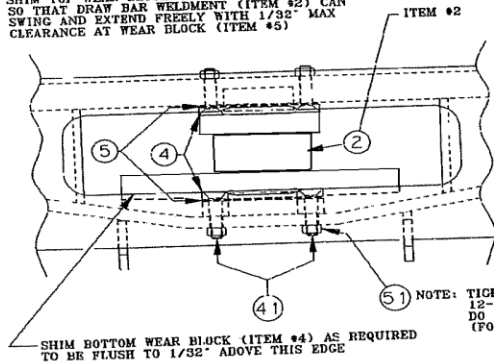

SHIM BOTTOM WEAR BLOCK (ITEM #4) AS REQUIRED TO BE FLUSH TO 1/32" ABOVE THIS EDGE

NOTE: TIGHTEN 5/16" NUT TO 12-15 FT-LBS DO NOT OVER TORQUE (FOUR PLACES)

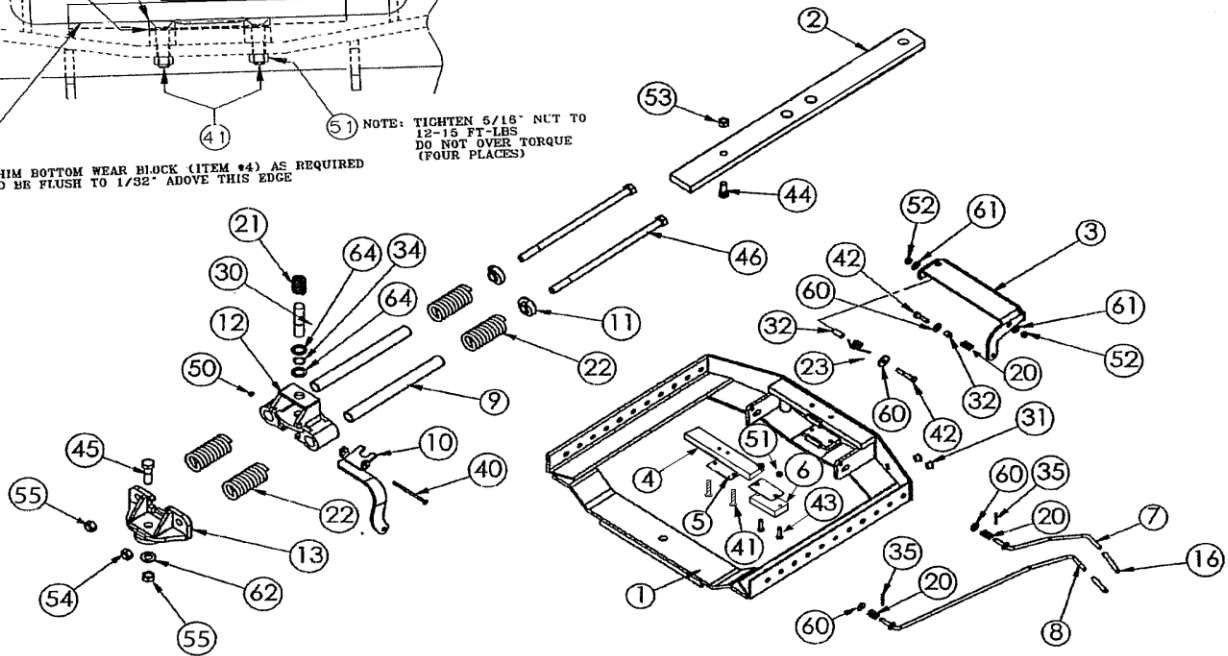

REF. NO.	PART NO.	QTY	DESCRIPTION
-	47090001	-	Cush'n Combo Frame Assembly
1	47070007F	1	Bumper Frame Weldment
2	47070023	1	Towbar
3	47077640DL1	1	Lock, Slide Swing
4	44003804	1	Wear Block (Bottom)
5	47077426	1	Shim, Wear Block .020"
6	44003007	A/R	Wear Block (Top)
7	47077485	1	Handle, Slide Lock
8	47077480	1	Handle, Pin Lever
9	47070010	2	Pipe
10	47077470	1	Lever
11	20092160	2	Spring Retainer Casting
12	20092161	1	Spring Mount Casting
13	20092170	1	Towbar Mounting Casting
16	30003400	2	Plastic Cap, Handle
20	24108100	3	Compression Spring, Handle
21	24111201	1	Compression Spring, Lock Pin
22	24140610	4	Compression Spring, Cushion
23	24512512	1	Torsion Spring, Slide Lock
30	47077250	1	Pin, Draw Bar Lock
31	30003300	2	Grommet, Black Plastic Snap-In
32	44003802	2	Pivot Bushing, 1-1/8" Long

REF. NO.	PART NO.	QTY	DESCRIPTION
34	14610100	1	Snap Ring, Draw Bar Pin
35	14700502	2	5/32" x 1-1/2" Cotter Pin
40	16004184	2	1/4"-20 x 4-1/2" NC Hex Bolt
41	16900001	2	5/16"x1-3/4" NC Hex Bolt
42	16006095	2	3/8"-16 x 2-1/4" NC Hex Bolt
43	14525061	2	5/16"x2-1/2" NC Slotted Flat
44	16010075	1	5/8"-11 x 1-1/2" NC Hex Bolt
45	16912115	1	3/4"-10 x 2-3/4" GRD8 HHCS
46	16912645	2	3/4" x 16" NC Hex Bolt
50	14110401	1	1/4" NC Hex Nyloc Locknut
51	14010501	2	5/16" NC Hex Nyloc Locknut
52	14110601	2	3/8" NC Hex Nyloc Locknut
53	14111001	1	5/8" NC Hex Nyloc Locknut
54	14111201	1	3/4" NC Hex Nyloc Locknut
55	14001200	2	3/4" NC All Steel Hex Nut Grade 5
60	17006001	4	3/8" Washer
61	17006001	2	3/8" Washer
62	17112000	1	3/4" SAE ZP Flat Washer
64	17616011	2	1" Machine bushing Washer, 10 ga.